

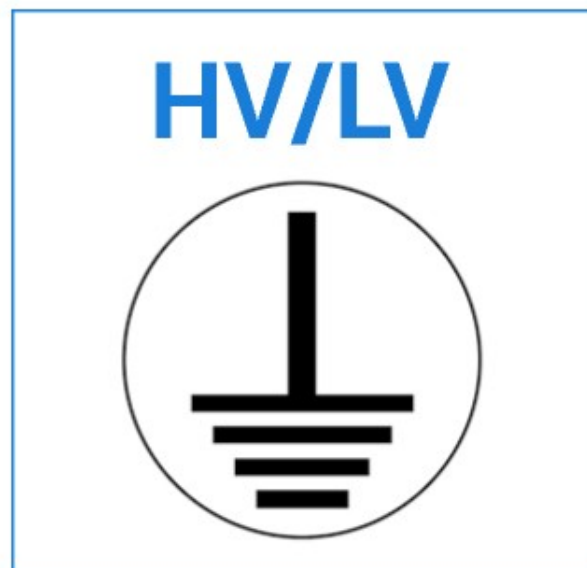

Segregated HV/LV Earthing Assessment

EEA Guide to Power System Earthing Practice Update



VS

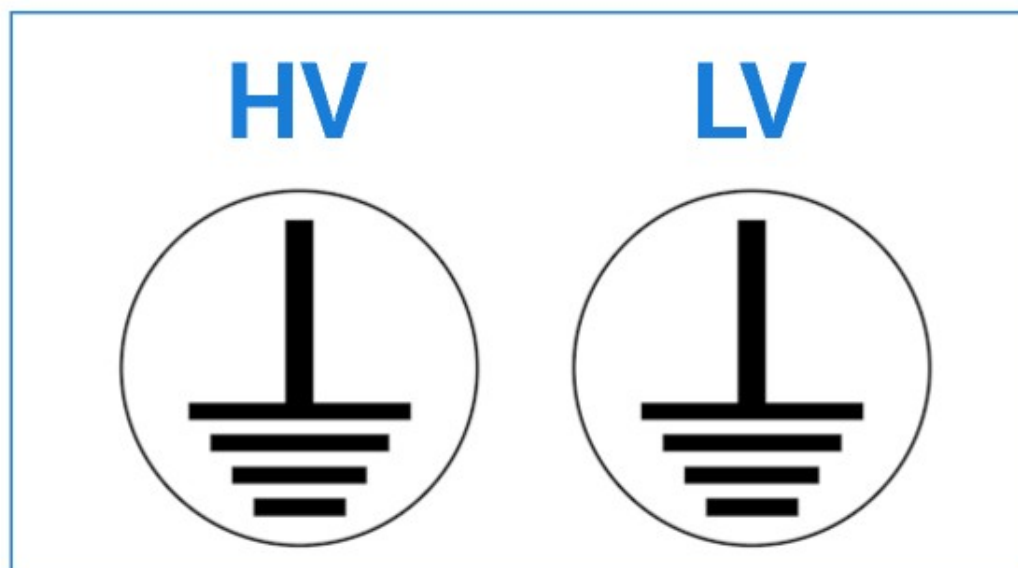



Combined HV/LV Earthing

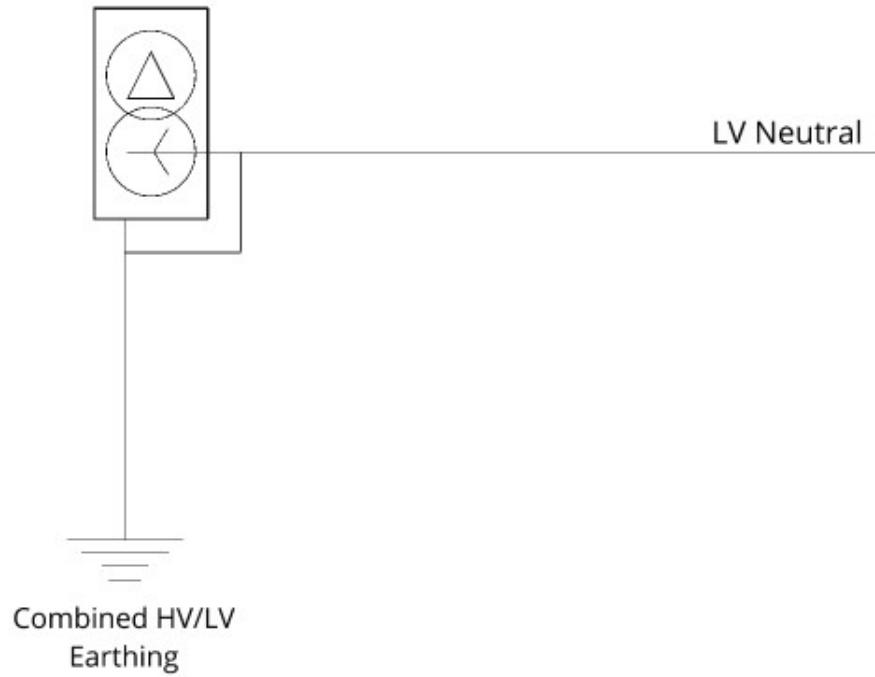

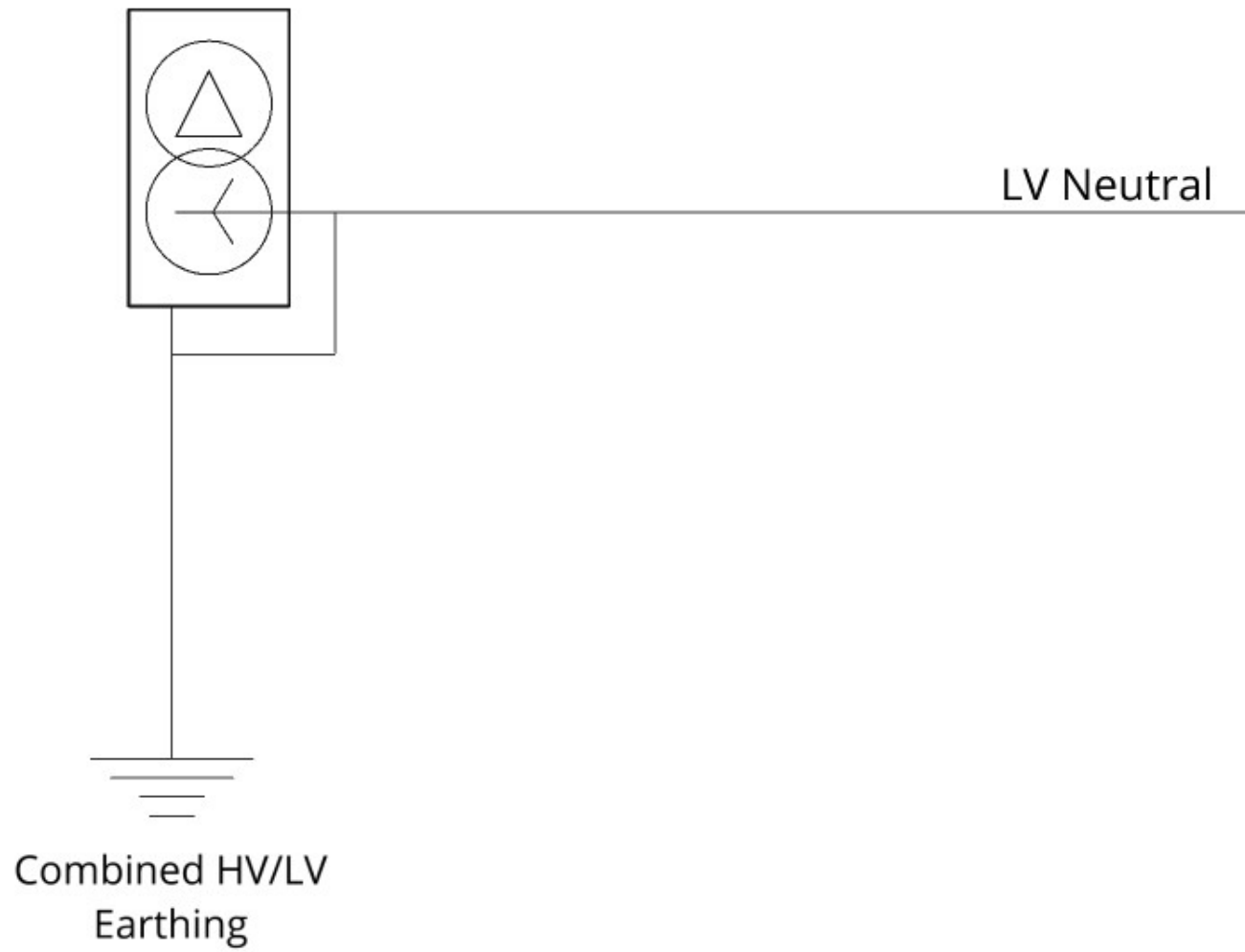

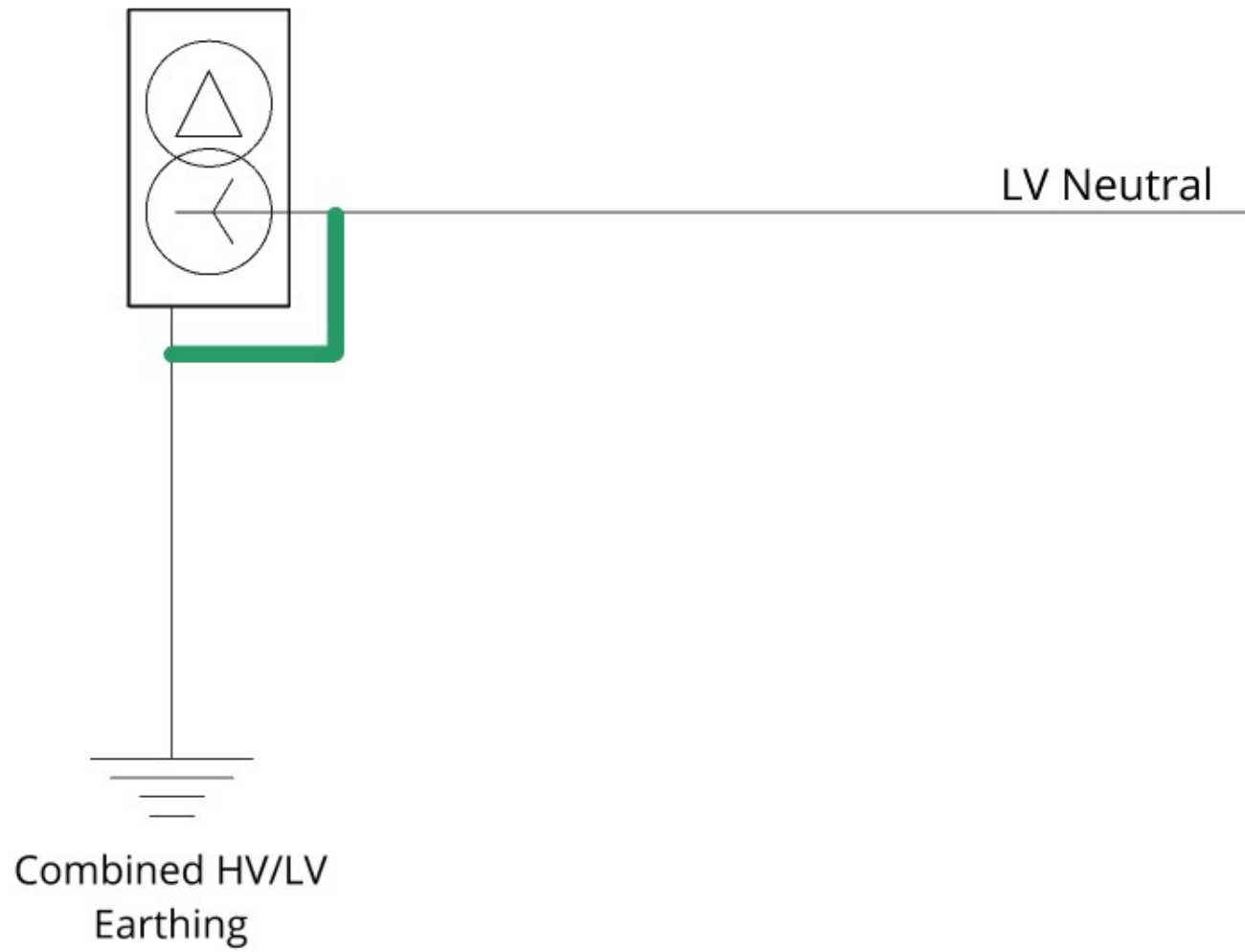



Segregated HV/LV Earthing Assessment

EEA Guide to Power System Earthing Practice Update

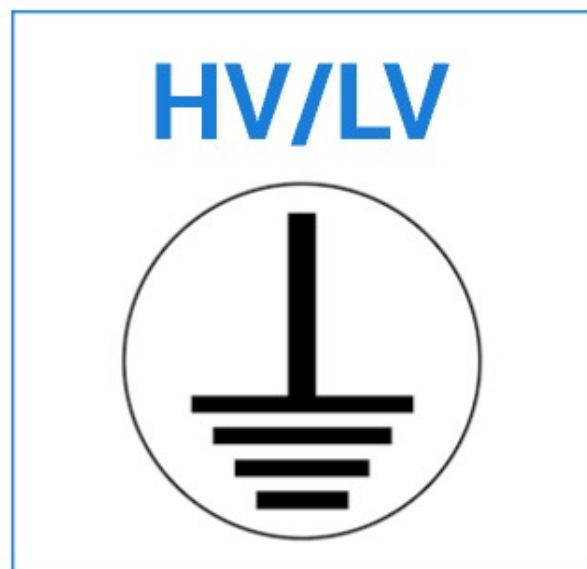

VS

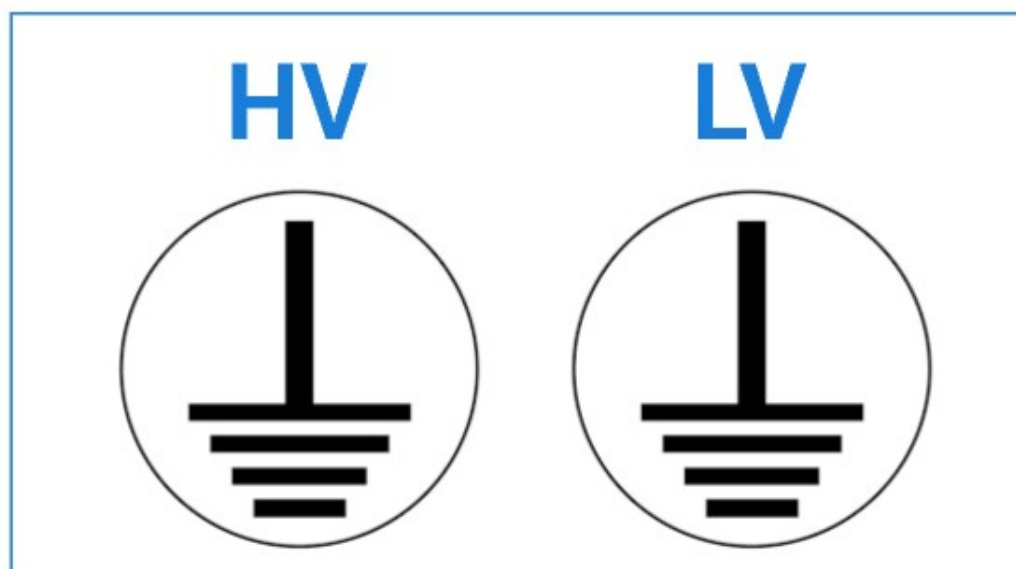



Segregated HV/LV Earthing

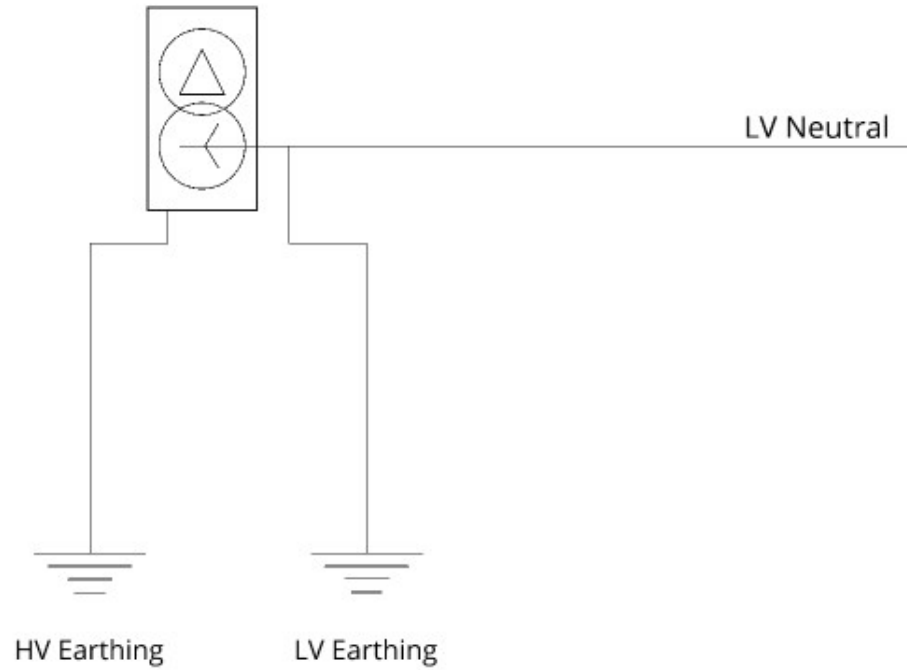

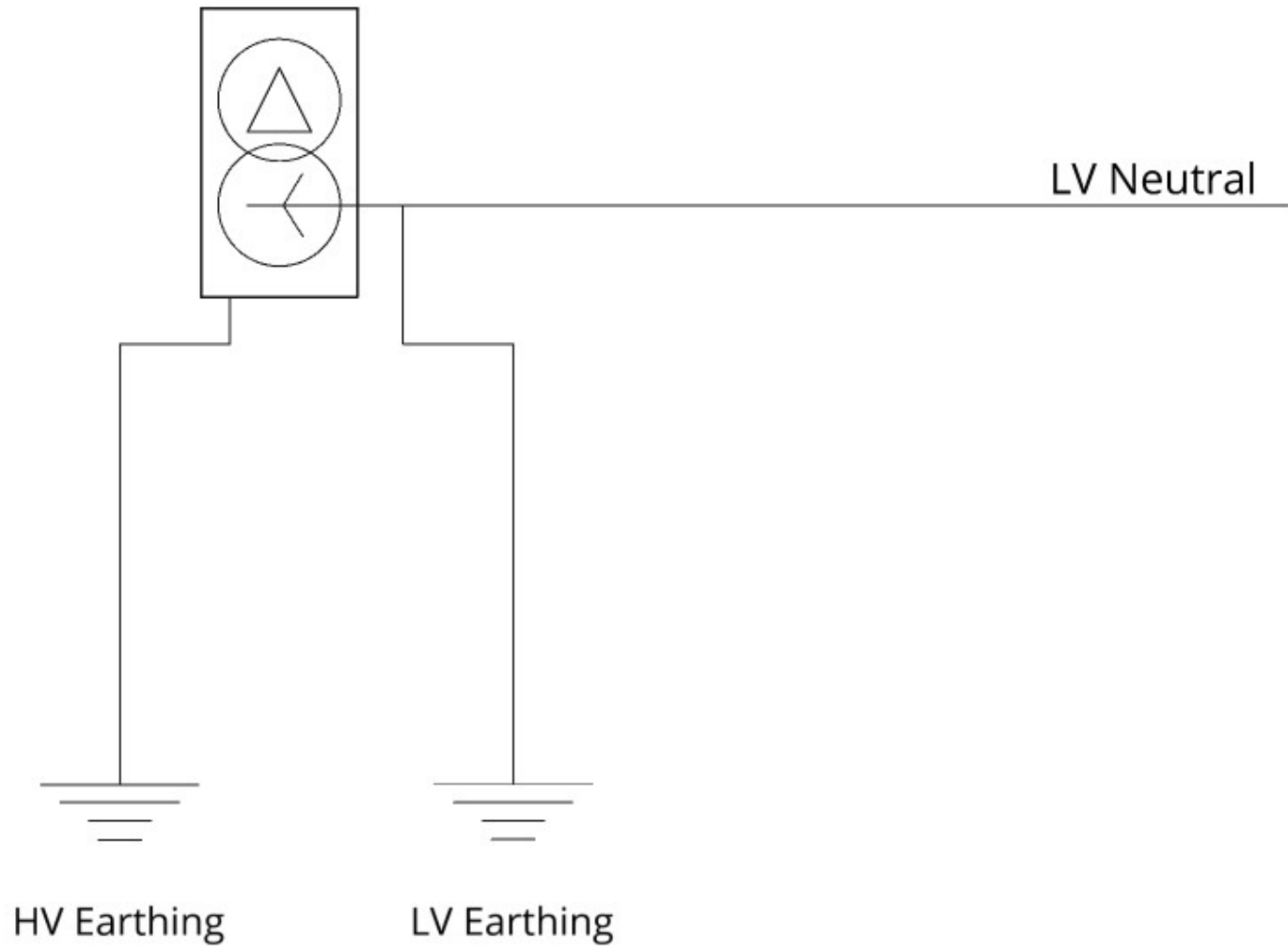



Segregated HV/LV Earthing Assessment

EEA Guide to Power System Earthing Practice Update

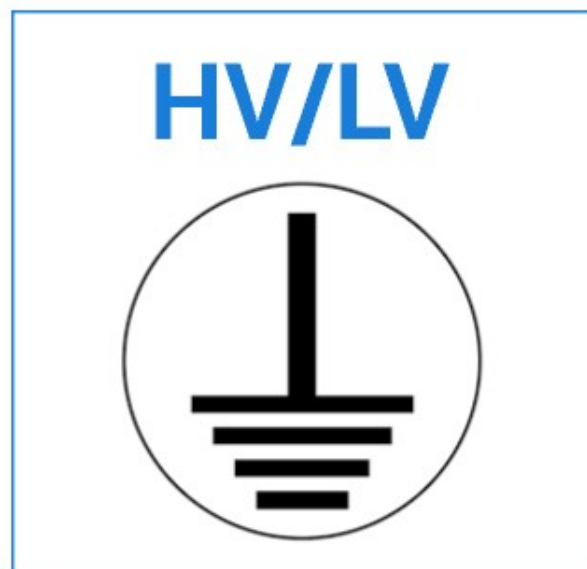

VS

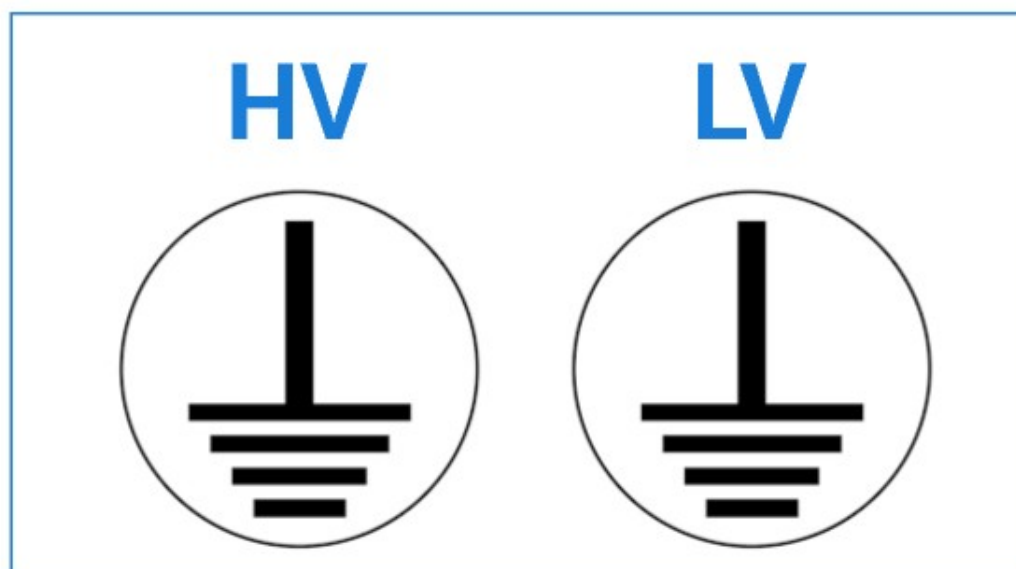



EEA Guide Update

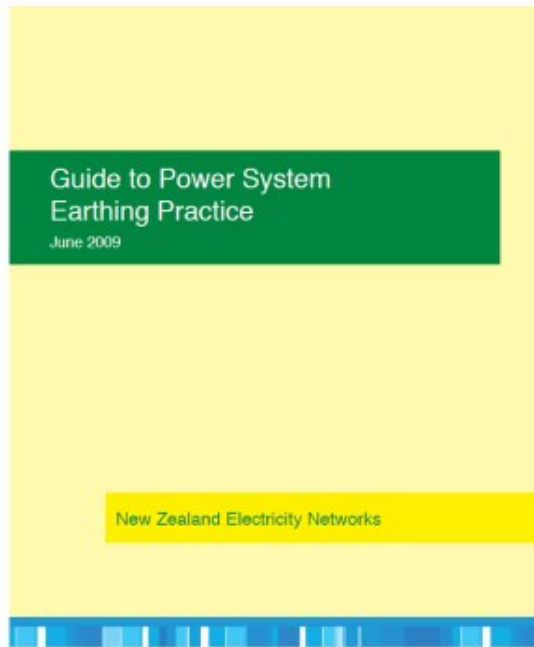

Electricity Engineers'
Association





Segregated HV/LV Earthing Assessment

EEA Guide to Power System Earthing Practice Update

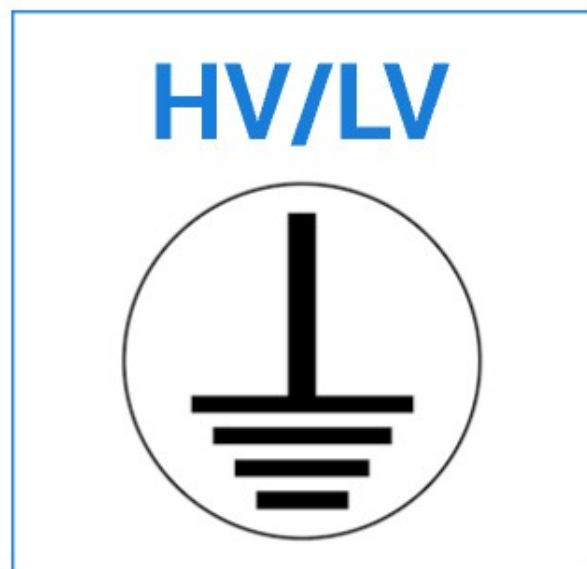

VS

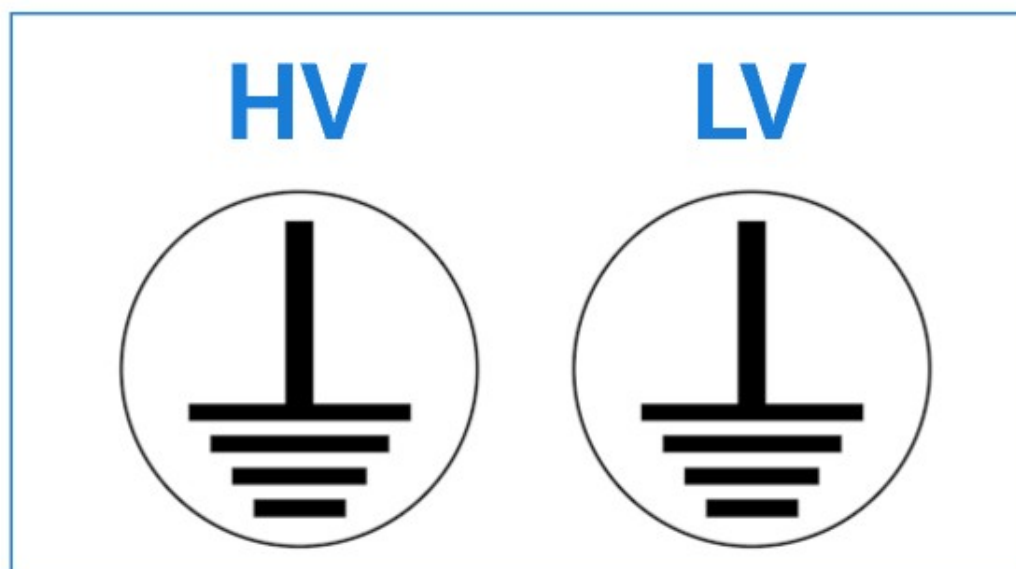



Assessment Overview

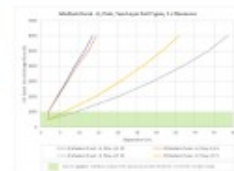

Table 9: Typical Minimum Separation Distances between HV and LV Earths for 11 kV Distribution Transformers

Size of MEN system	Size of HV earth electrode ^{NOTE 1}	Minimum separation distance (m)
Medium to large MEN system (> 50 customer earths)	Small	2
	Large	5
Small MEN system (5 to 50 customer earths)	Small	2
	Medium	5
Very small MEN system (< 5 customer earths)	Large	10 ^{NOTE 2}
	Small	10
	Medium	30 ^{NOTE 2}
	Large	50 ^{NOTE 2}



Inputs



Fault Data

Magnitude - 5 kA and 13 kA

Duration - 0.5 s, 1.0 s and 1.5 s

Fault Frequency - 1 in 30 years



Soil Resistivity - Regional representation



Earthing Systems - Steering Group Guidance



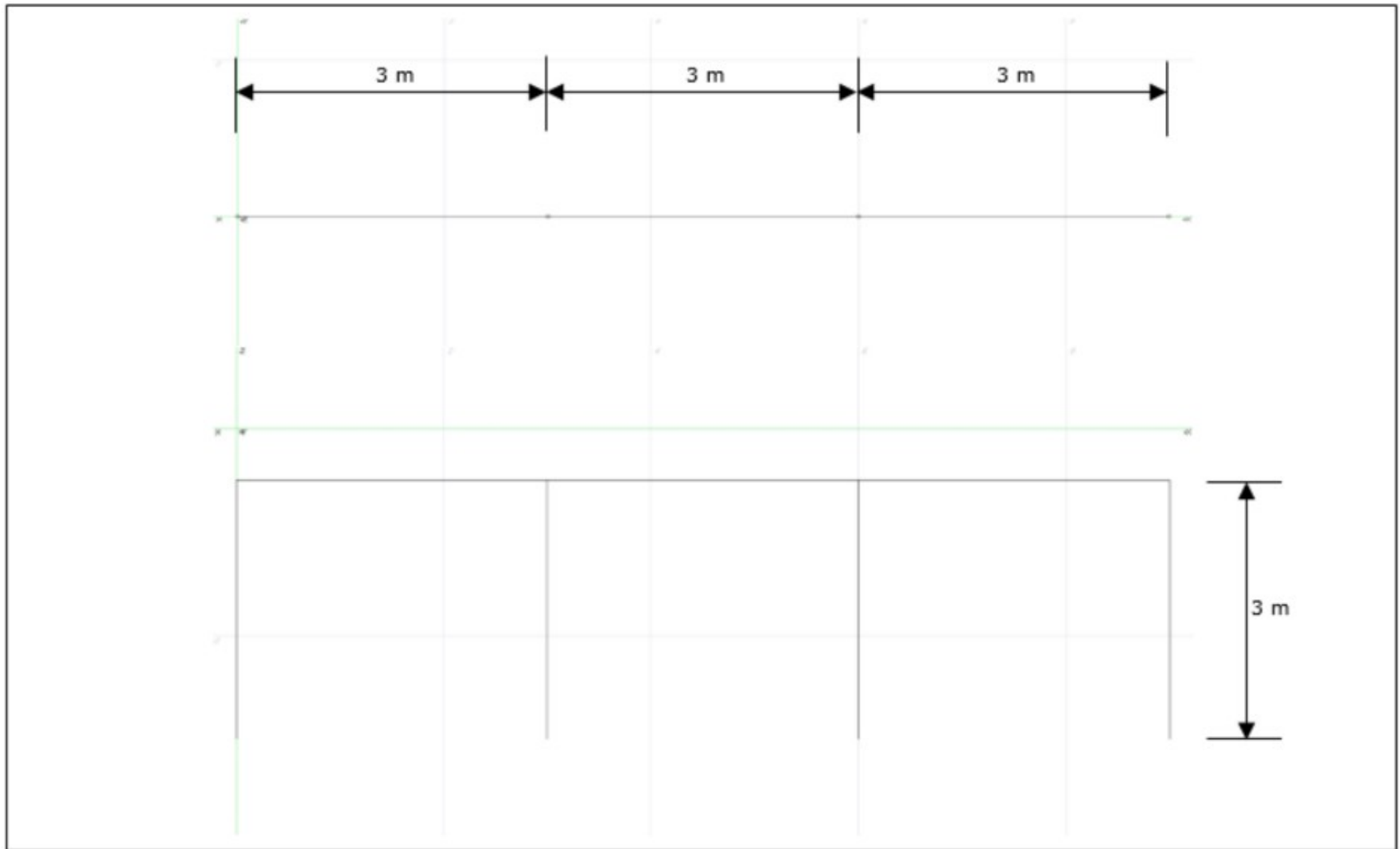

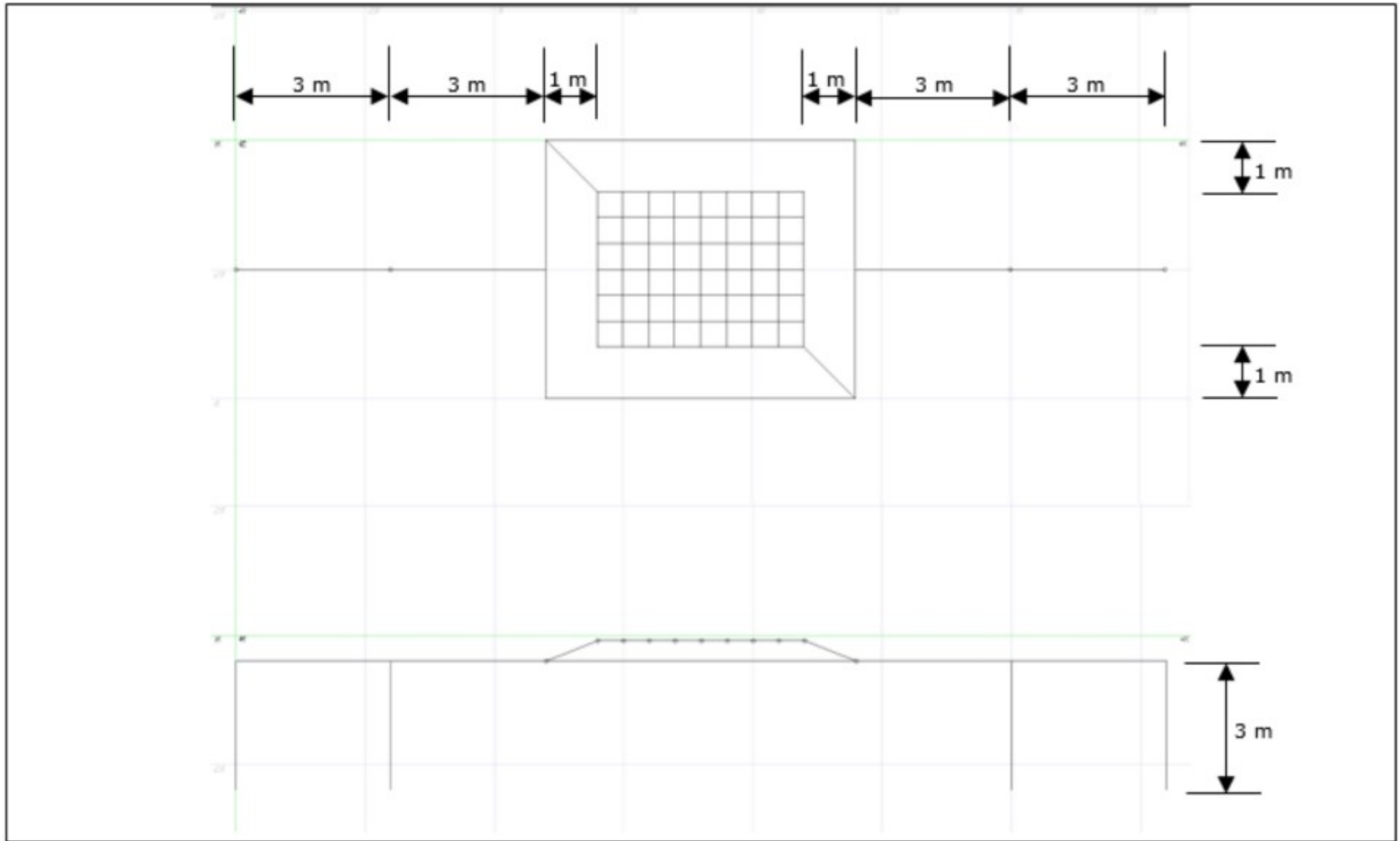



Methodology

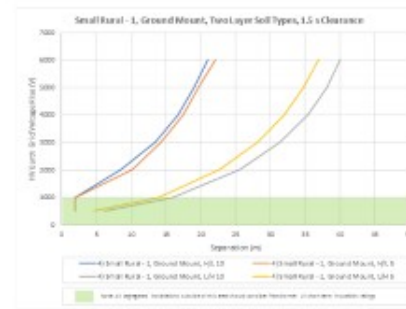
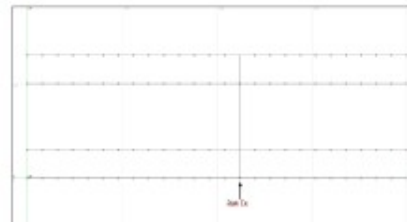
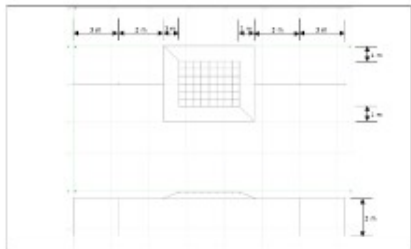
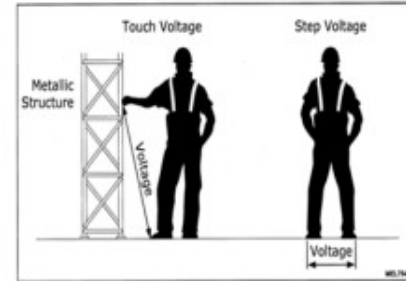
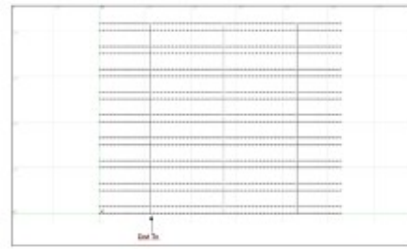
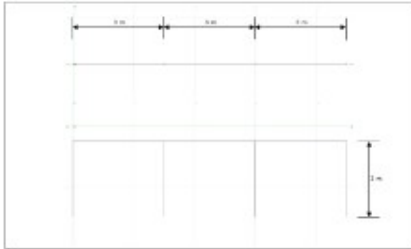

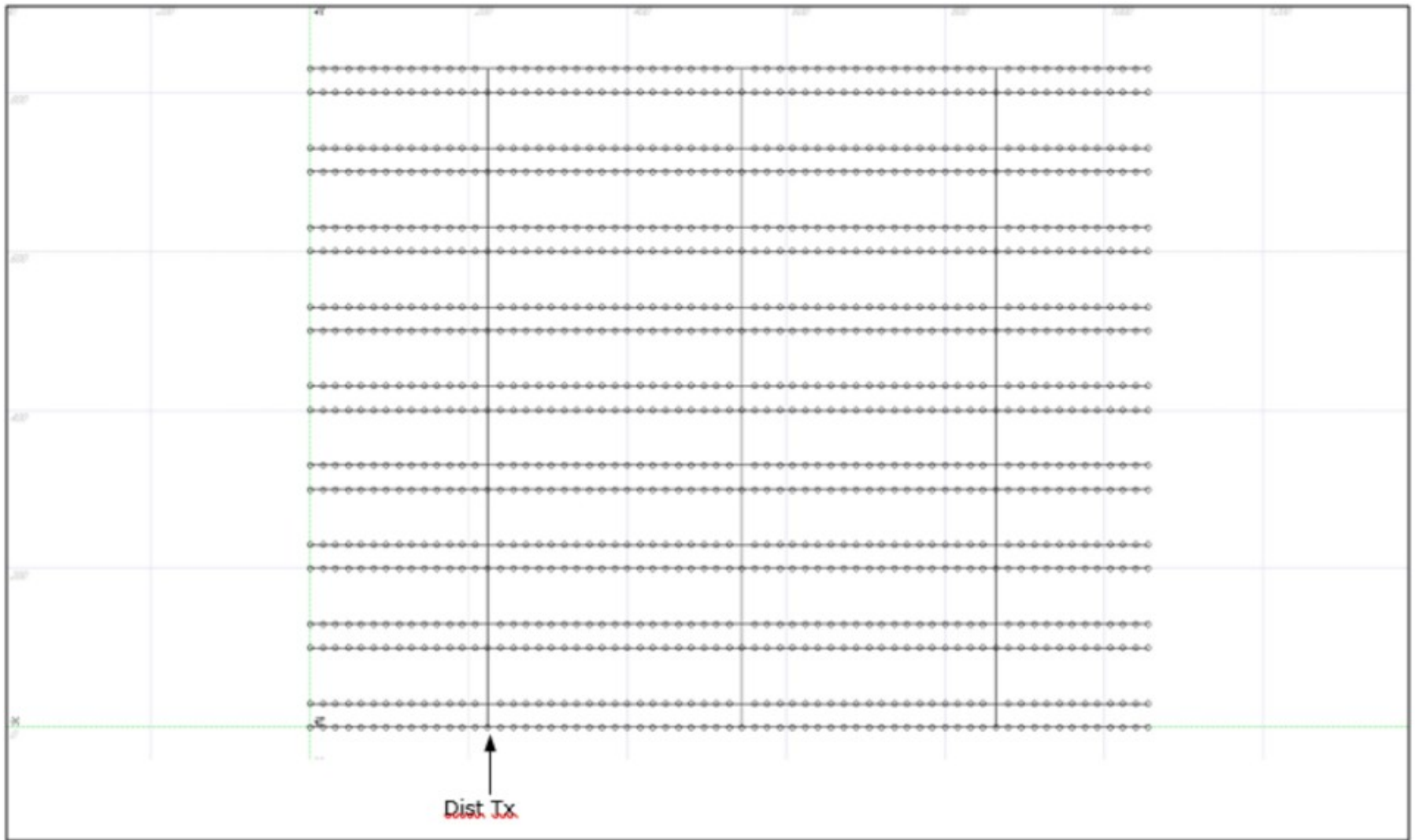



Methodology

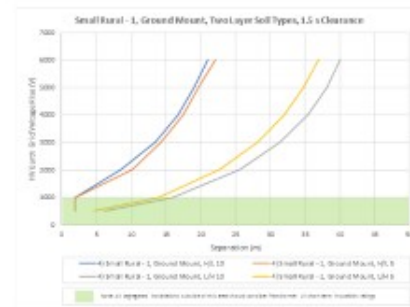
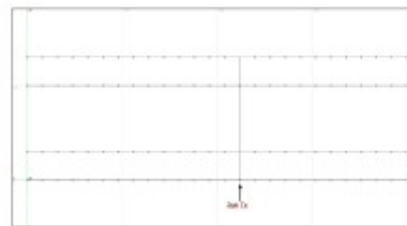
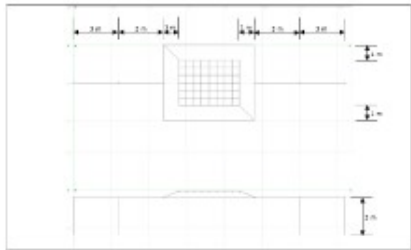
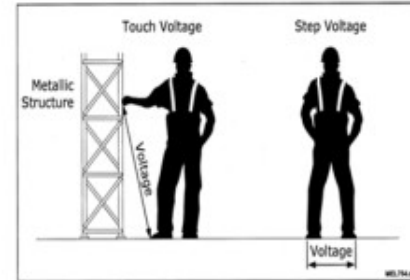
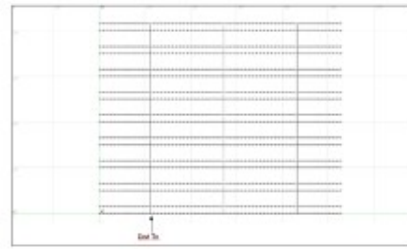
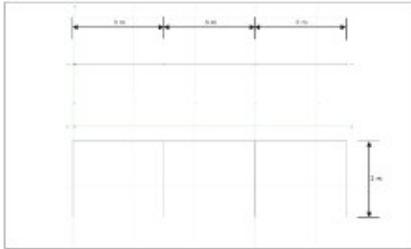

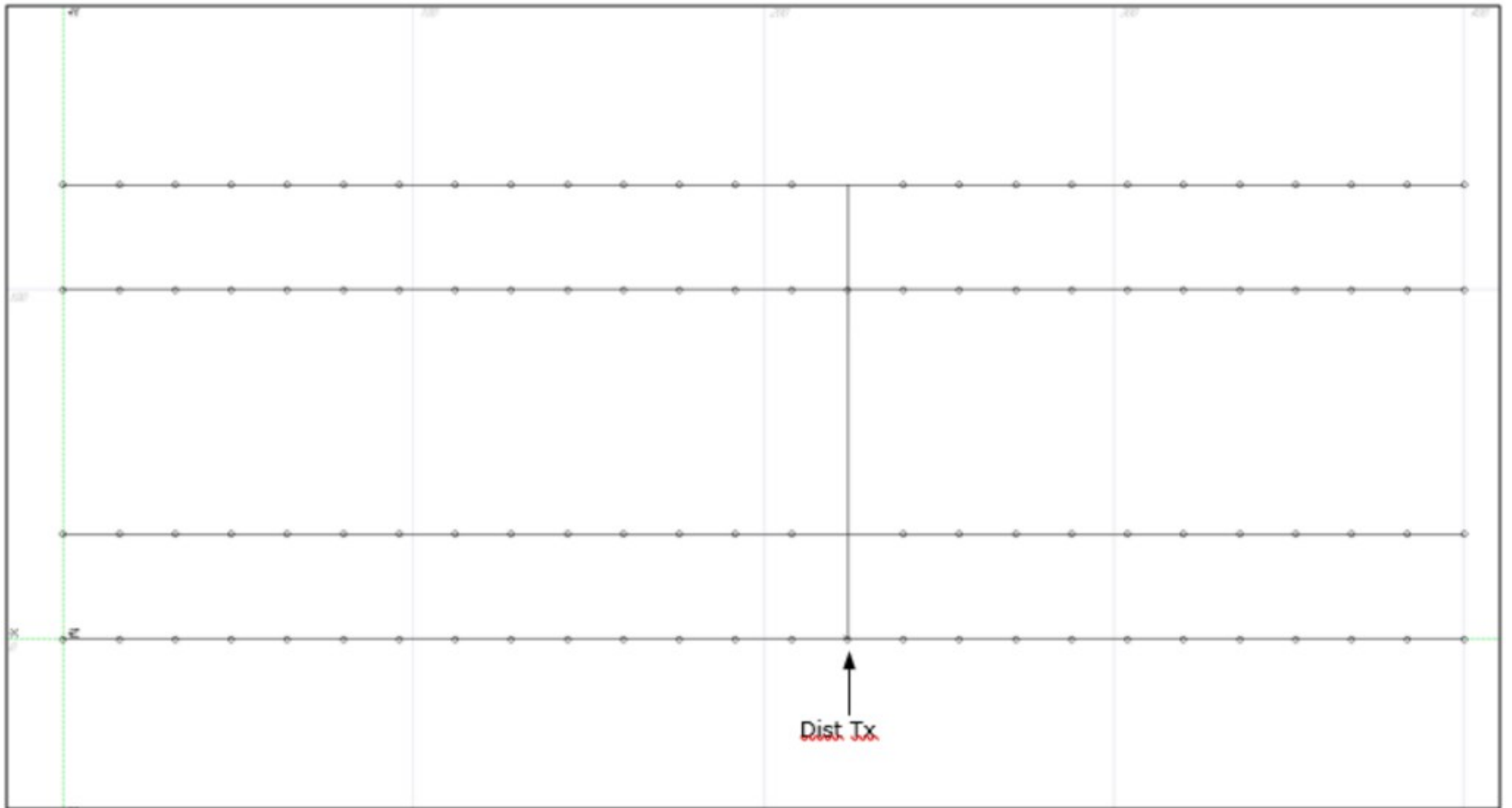

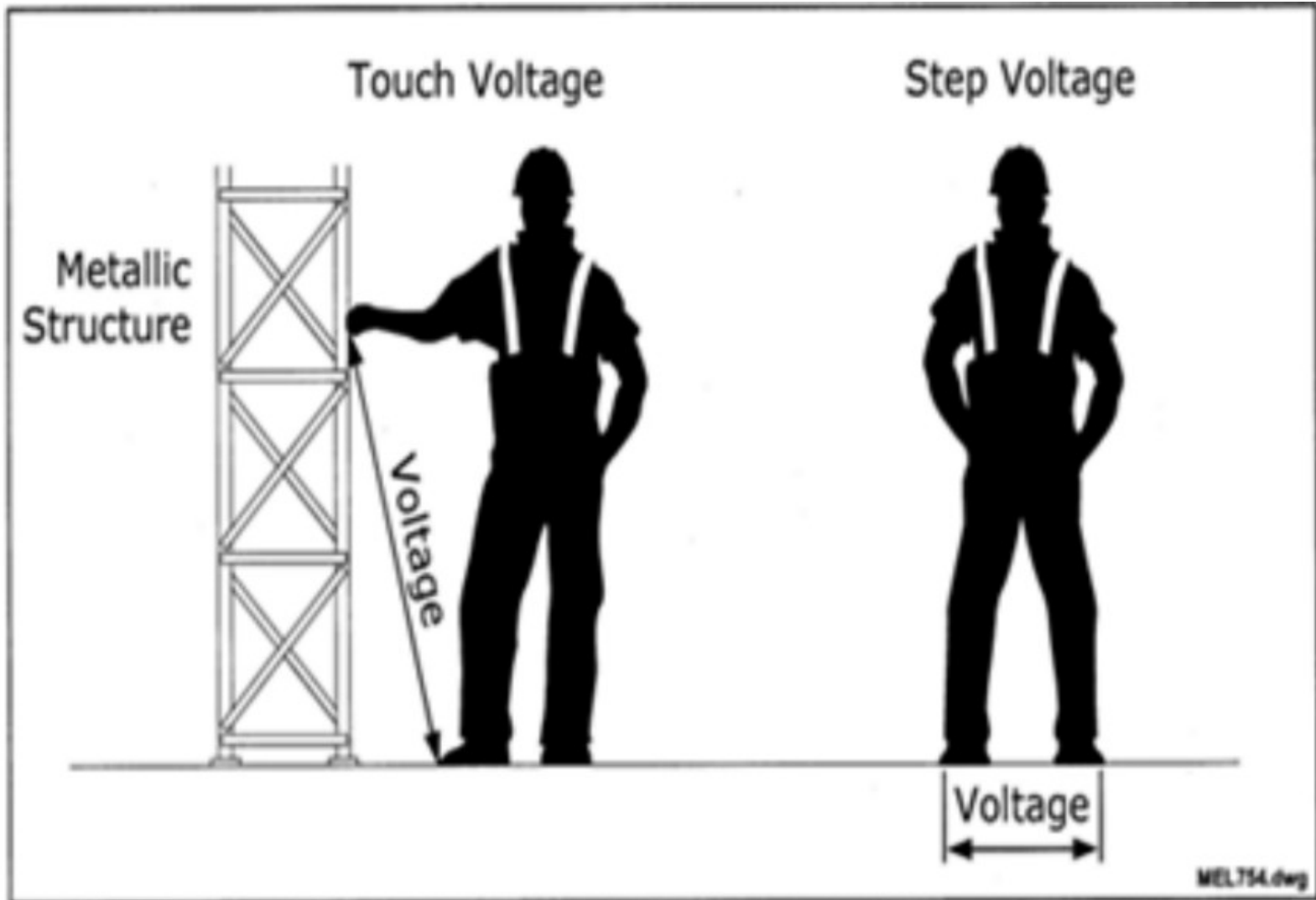

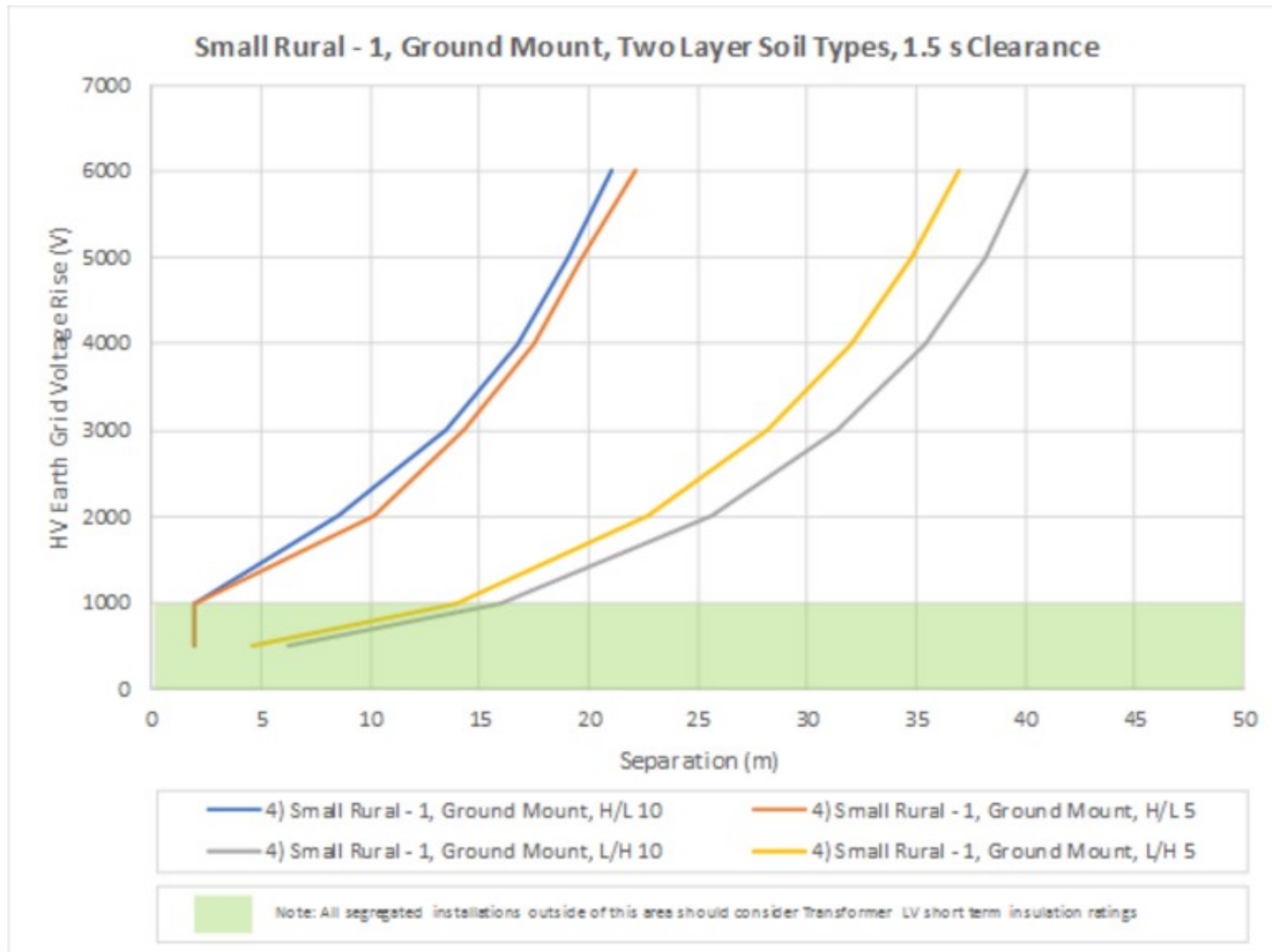



Methodology

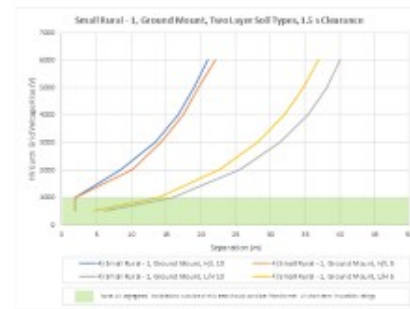
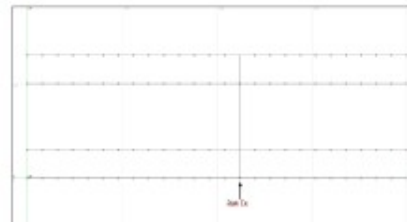
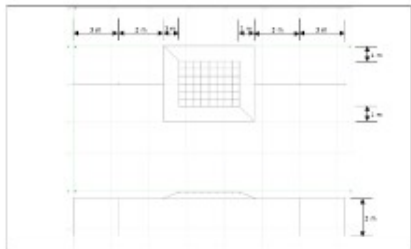
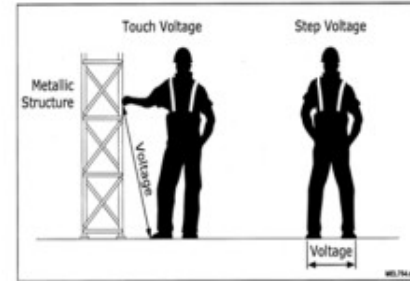
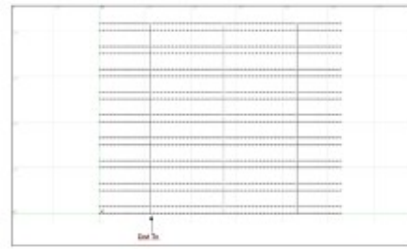
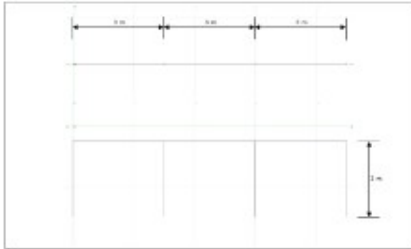



Outcomes

No definitive result

Scenario specific decisions

In General:

- Small Rural MEN - Segregated
- Urban - Combined

Required separation - 2 m to >50 m

HV Earth - High EGVR

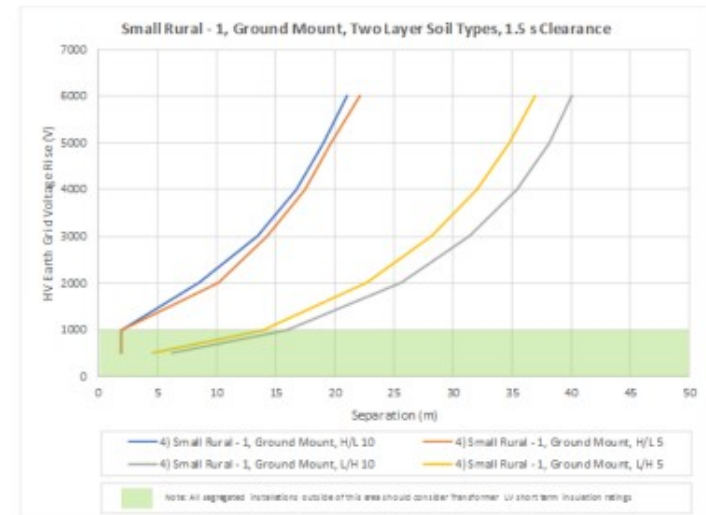

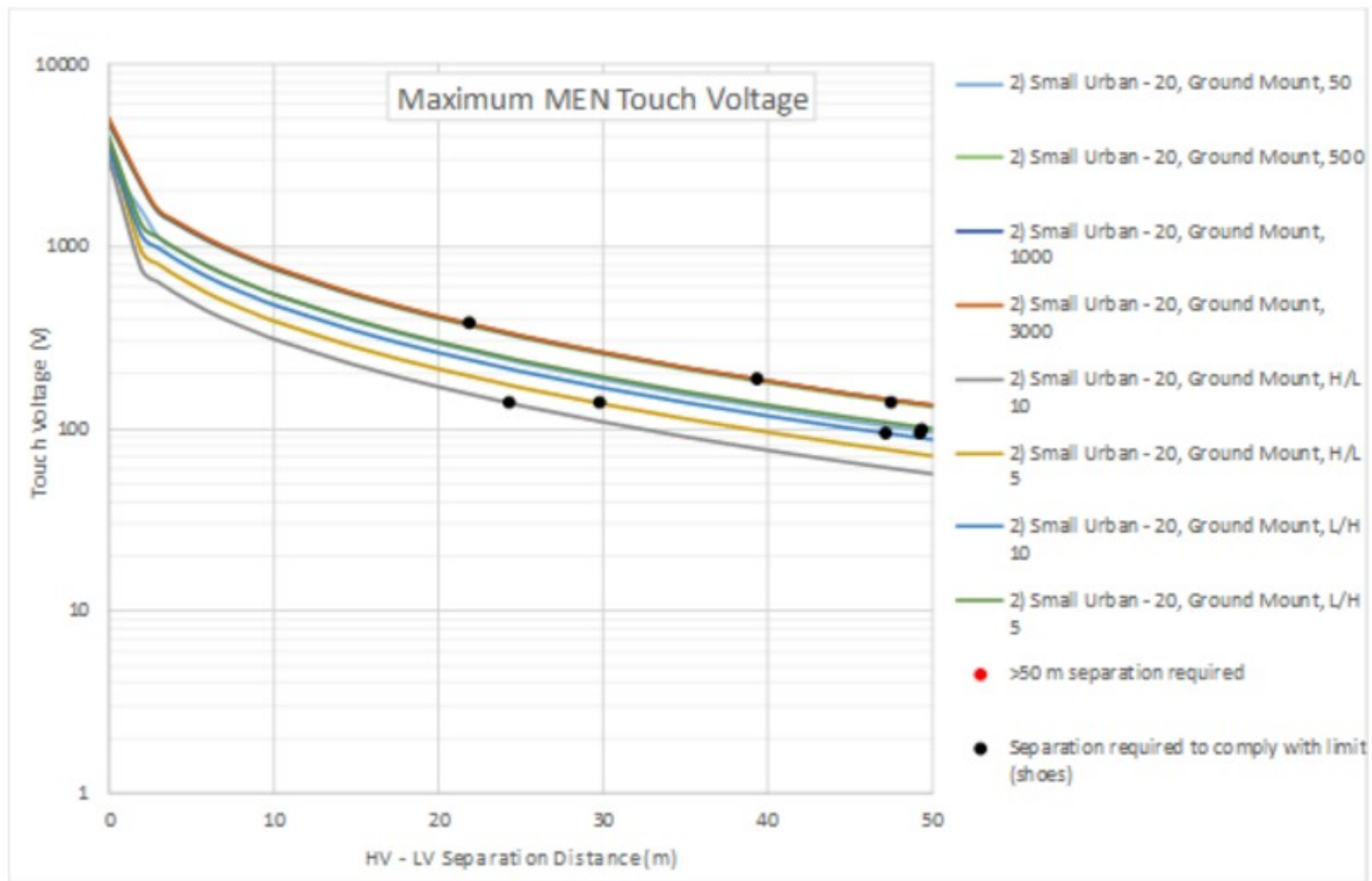

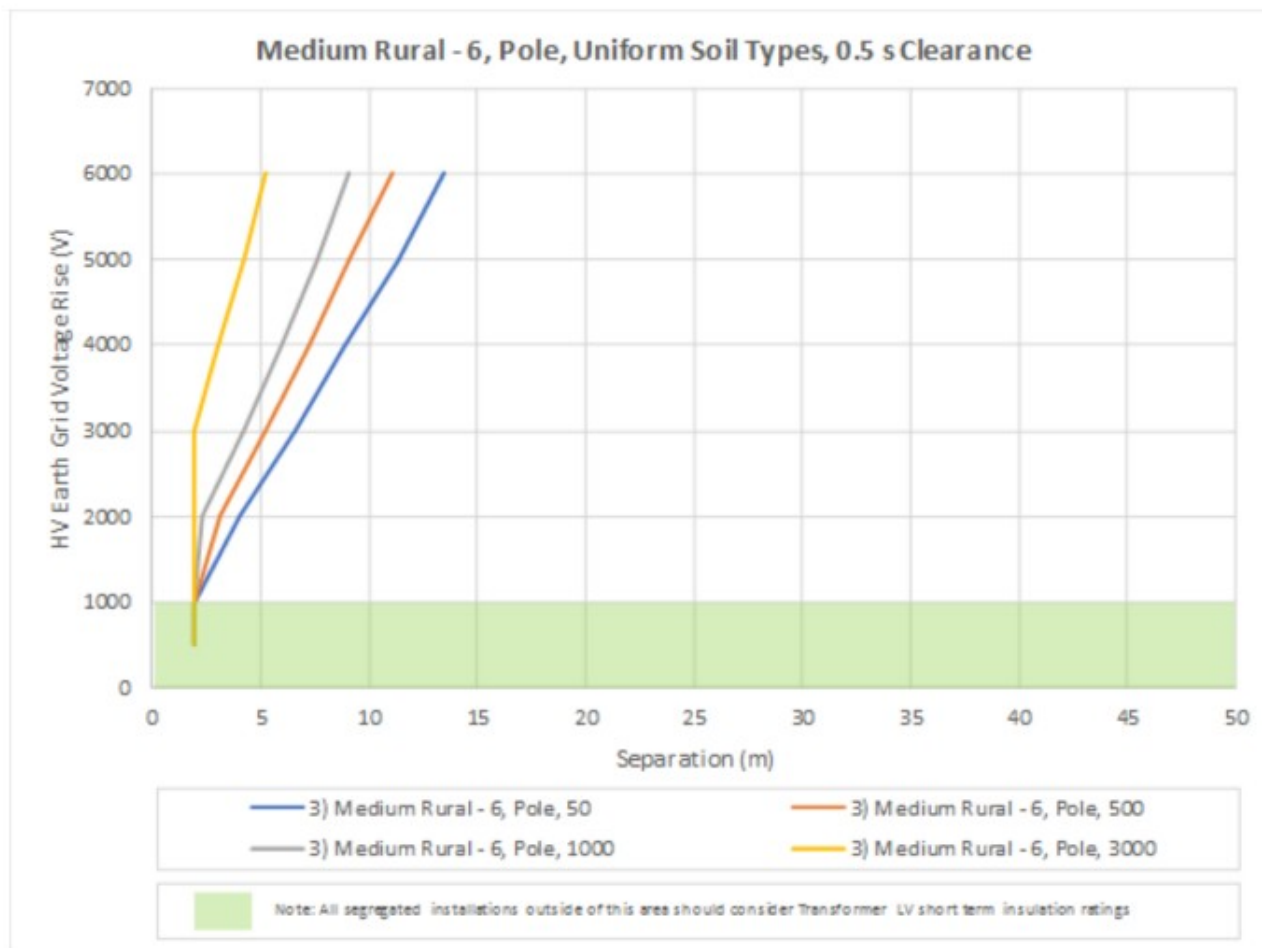

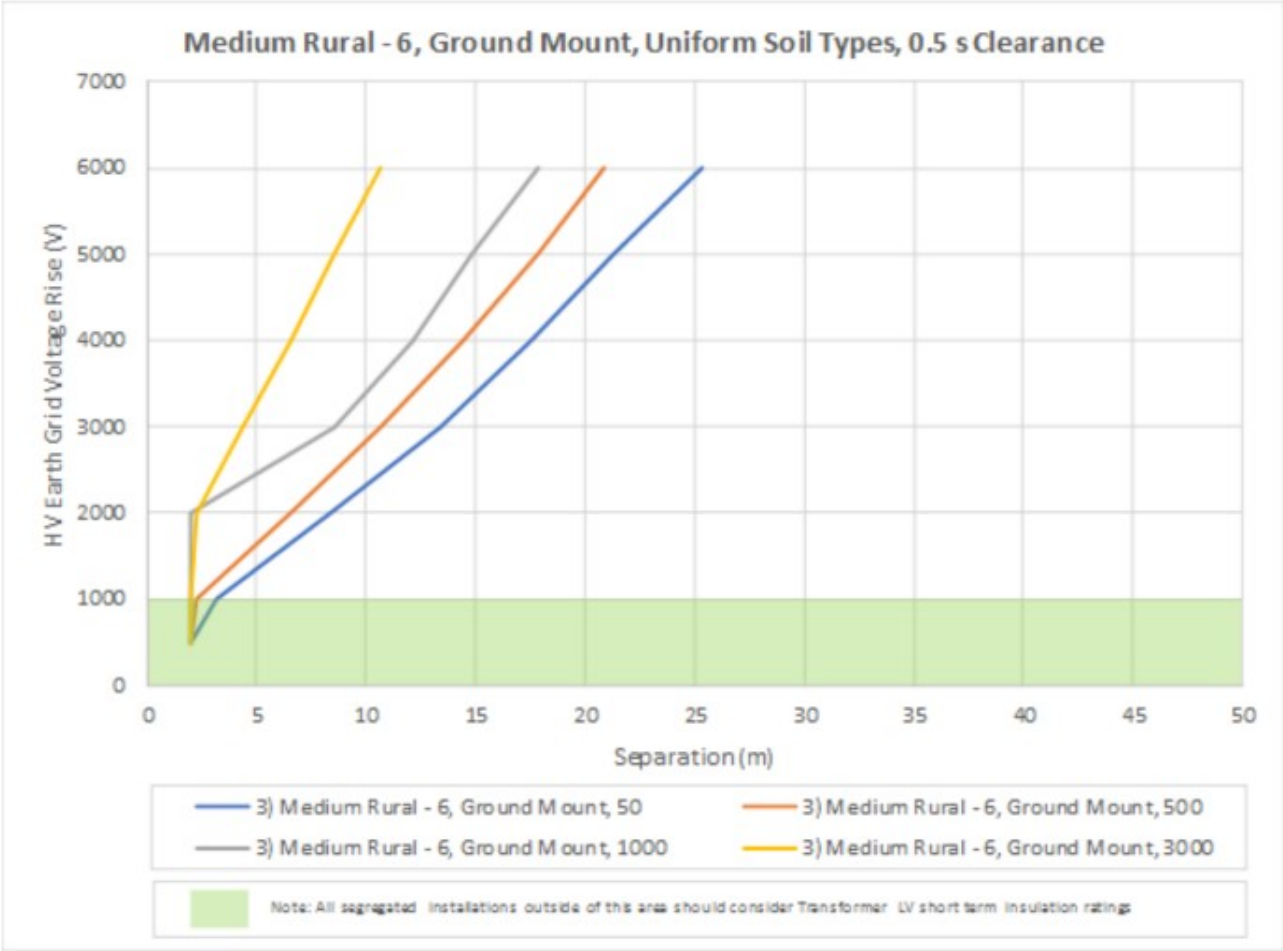

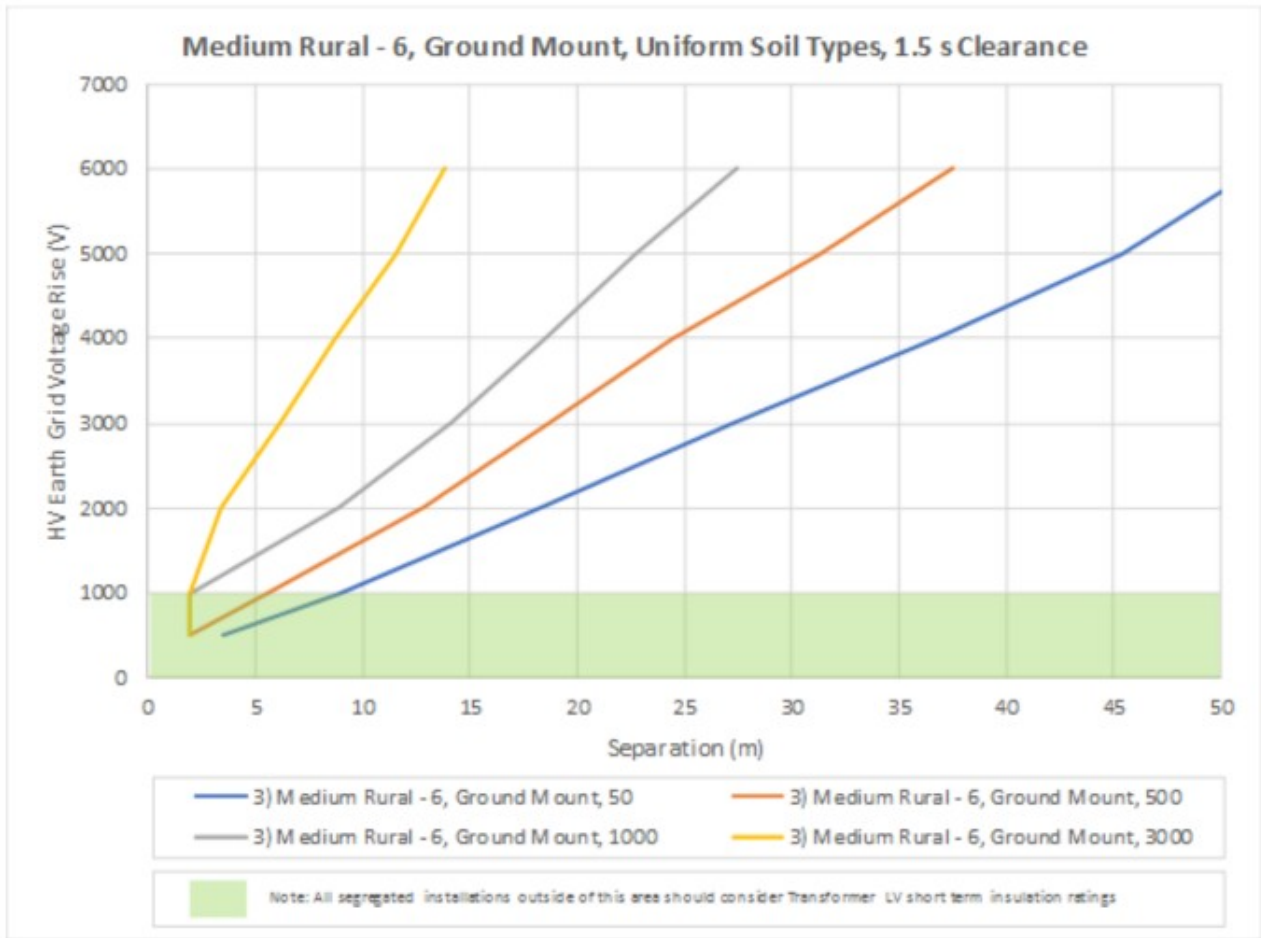

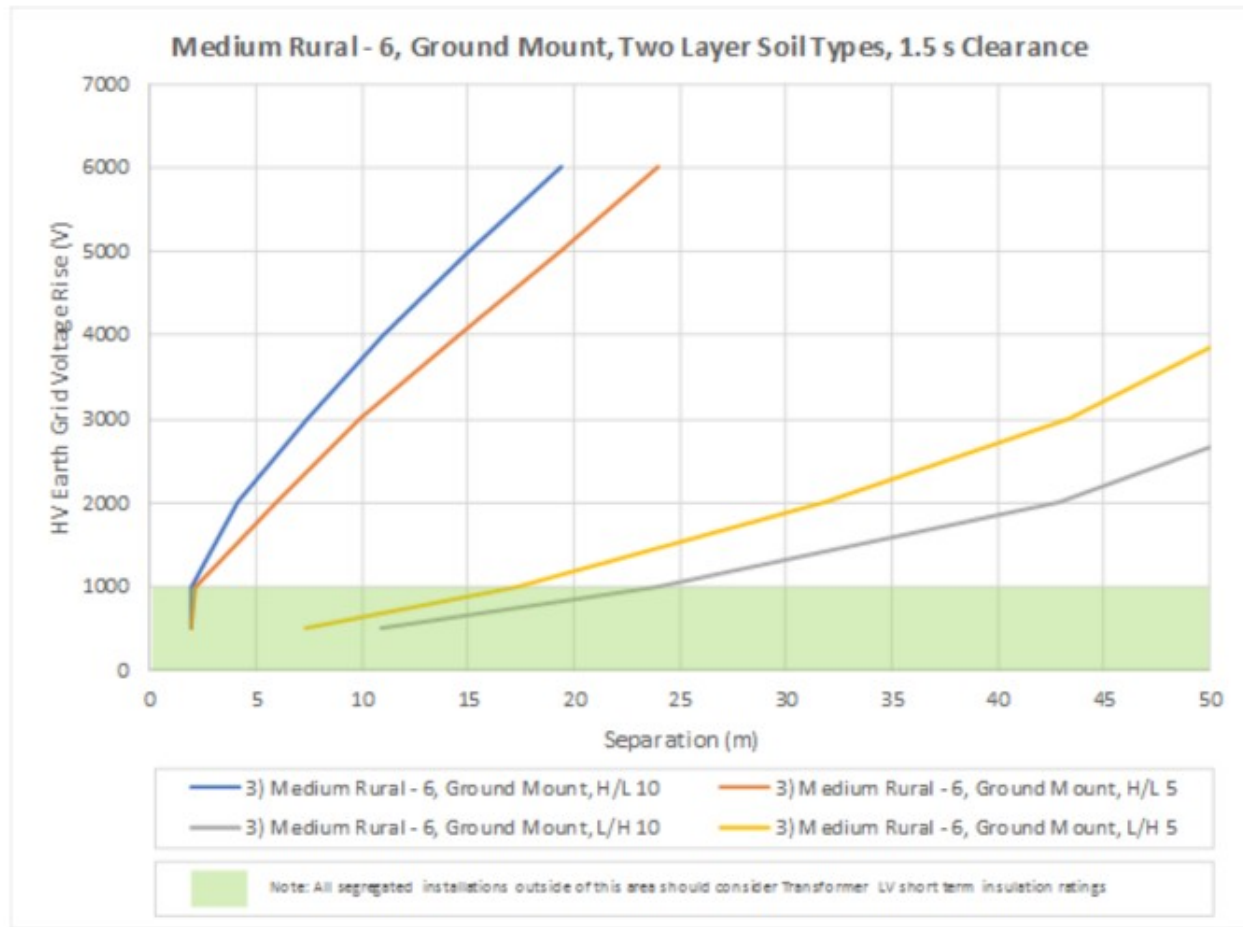



Recommendations and Considerations

1. Extent of HV/LV earthing
2. Transformer LV winding insulation ratings
3. Fault duration
4. Soil resistivity structure
5. HV earthing connections
6. Transformer location
7. Separate conductive items
8. Overhead considerations
9. HV to LV clash
10. Lightning strikes
11. LV Faults on tank
12. Maintenance of separation



Segregated HV/LV Earthing Assessment

EEA Guide to Power System Earthing Practice Update

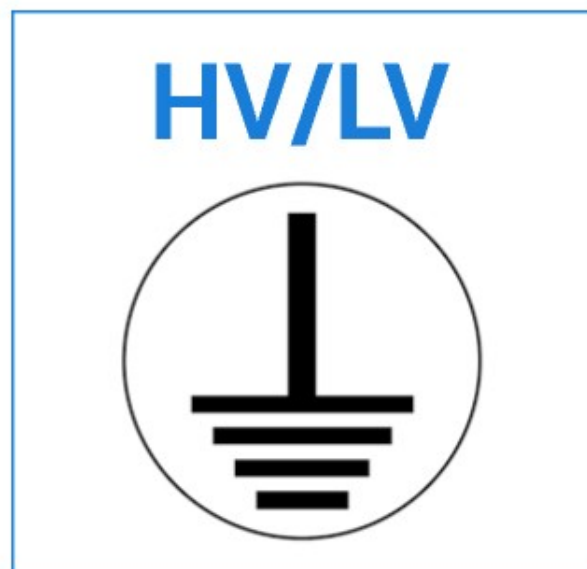

VS

